

G. L. Nause Company, Inc.  
Lifetime® Wagons  
1971 Phoenix Drive  
Loveland, Ohio 45140  
(513) 722-9500  
www.GLNause.com

**Bill of Material**  
**Hoelscher Model 1000**  
**Push Over Arm Retro Fit Kit**  
For Serial #04236 (2006) and Later

**PERFORMANCE  
SATISFACTION GUARANTEED  
OR  
YOUR MONEY BACK**

For Serial #04335 and earlier slight modification or replacement of Push Over Arm is required.



## **WARNING!**

**BEFORE STARTING THIS INSTALLMENT, COMPLETELY DISCONNECT THE ACCUMULATORS HYDRAULIC'S SYSTEM FROM THE POWER SUPPLY.**

Please refer to the enclosed drawings for part illustration and location.

Underneath the machine, remove the lower pin connecting the hydraulic cylinder to the push over arm.

Attach the two guide plate's (item 2 ) to the inside of each ( LEFT AND RIGHT ) tube's top two pre drilled holes in the push over arm using 2 carriage bolts ( item 7 ) and 2 locking flange nuts ( item 9 ) each, softly snug each nut to the tube to allow for future adjustment.

Manually raise the push over arm to the up position.

Remove (if installed) the spring loaded extension arm, by removing two 3/8" bolts and discard.

With the push over arm in the up position, insert the long leg of the ski piston arm ( item 1 ) into the left guide plate (item 2 ) and ( start ) the short leg of the ski piston arm into the formed opening of the push over arm. Prior to inserting the long leg of the ski piston arm ( item 1 ) into the right side guide plate ( item 2 ) slide, in order, 2 stop collars (item 5 ) and 1 return spring ( item 6 ) onto the long leg of the ski piston arm ( item 1 ) then insert the long leg of the ski piston arm ( item 1 ) into the right side guide plate ( item 2 ).

Lower the push over arm to the down position.

Attach the bale stop (item 3) under the bale through and ramp with two hex bolts (item 8) and 2 locking flange nuts (item 9). Two 13/32" holes may have to be drilled using the locations supplied on the drawings. **(The bale stop will help prevent any scuffing or tearing to the end of a long bale exiting the bale chamber. This may occur when the bale pushes the ski piston arm to its maximum contraction.)**

At this time, make sure the ski piston arm slides back and forth with no resistance. The guide plates must be adjusted so that the bottom of the ski arm is not rubbing the top of the push over arm; (about 1/16" + clearance should be achieved) continuing to adjust the guide plates so the ski piston arm moves freely with no resistance. Finish tightening the mounting nuts (items 9) to assure guide plates will not slip.

Slide the ski piston arm (item 1) 1" from the ramp and bale stop. Slide the left side stop collar (item 5) firmly against the left side guide plate (item 2) and tighten. Slide the return spring ( item 6 ) firmly against the right side guide plate ( item 2 ) slide the right stop collar against the return spring until the spring retracts ½ " and tighten the stop collar.

## **WARNING!**

**DO NOT COLLAPSE THE RETURN SPRING ANY FURTHER, VERY LITTLE TENSION IS NEEDED. IT WILL RECEIVE TENSION WHEN IT CONTACTS THE BALE OF HAY. The length of the spring at the proper setting should measure approx. 11 ½" between the guide plates.**

## **NOTE!**

Make sure that the set screws, in the stop collars, sets properly into the ski piston arm. The set screws are ground to a point and will create an indentation into the pipe to assure the stop collars will not slip.

Push or pull the ski piston arm toward the rear of the machine and release quickly. You should experience a rapidly return of the ski piston arm. Do this about six times. A rapid return means you have achieved proper alignment. Some adjusting or tweaking of the guide plates may be required to assure proper alignment.

**We recommend applying a TEFLON BASED SPRAY LUBRICANT to the pipe at the two guide plate sliding locations. We recommend using (ZEP 2000) you can purchase it at GRAINGER (Product # 5DPV9).**

**Make sure there is 8" min. distance between the end of the ski piston arm pipe and the forward point of the control arm. This will assure no damage to the control arm when the ski piston arm is fully retracted while the push over arm is returning to the down position.**

**Line up the bale fence (item 4) with the inside face of the accumulator frame; mark the location of the holes, center punch, and drill three 21/64" holes. Install the fence with self tapping screws (item 10) be sure to lubricate the self tapping screws before inserting. The fence will prevent any short bales exiting the bale chute from being ejected from the machine when the push over arm is returning to the down position.**

**At this time we strongly recommend checking the setting of the control arm and detent. Please refer to page 13 of your operator's manual for the recommended settings.**

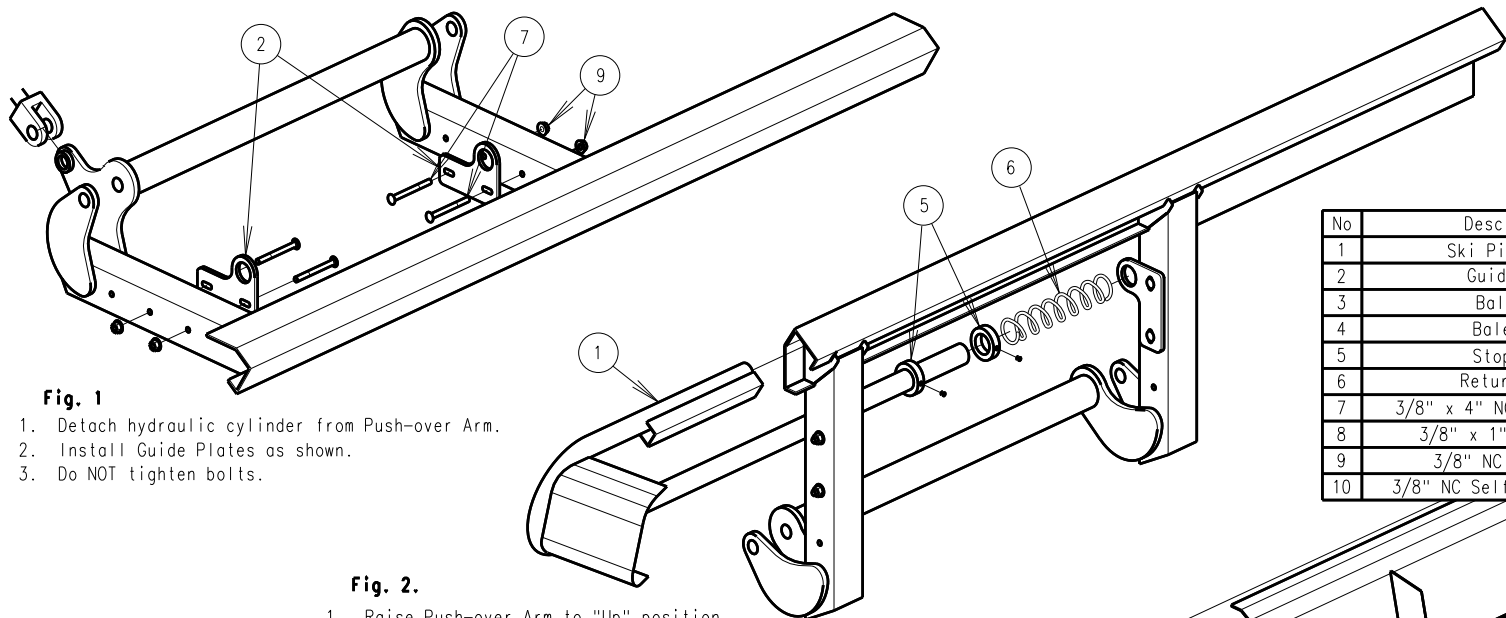

No	Description	Part No	Qty
1	Ski Piston Arm		1
2	Guide Plate		2
3	Bale Stop		1
4	Bale Fence		1
5	Stop Collar		2
6	Return Spring		1
7	3/8" x 4" NC Carriage Bolt		4
8	3/8" x 1" NC Hex Bolt		2
9	3/8" NC Flange Nut		6
10	3/8" NC Self Threading Screw		3

**Fig. 1**

1. Detach hydraulic cylinder from Push-over Arm.
2. Install Guide Plates as shown.
3. Do NOT tighten bolts.

**Fig. 2.**

1. Raise Push-over Arm to "Up" position.
2. Insert long leg of Ski Piston into front Guide Plate.
3. Install two Stop Collars and Spring onto Ski Piston.
4. Insert short leg of Ski Piston into front of Push-over Arm.

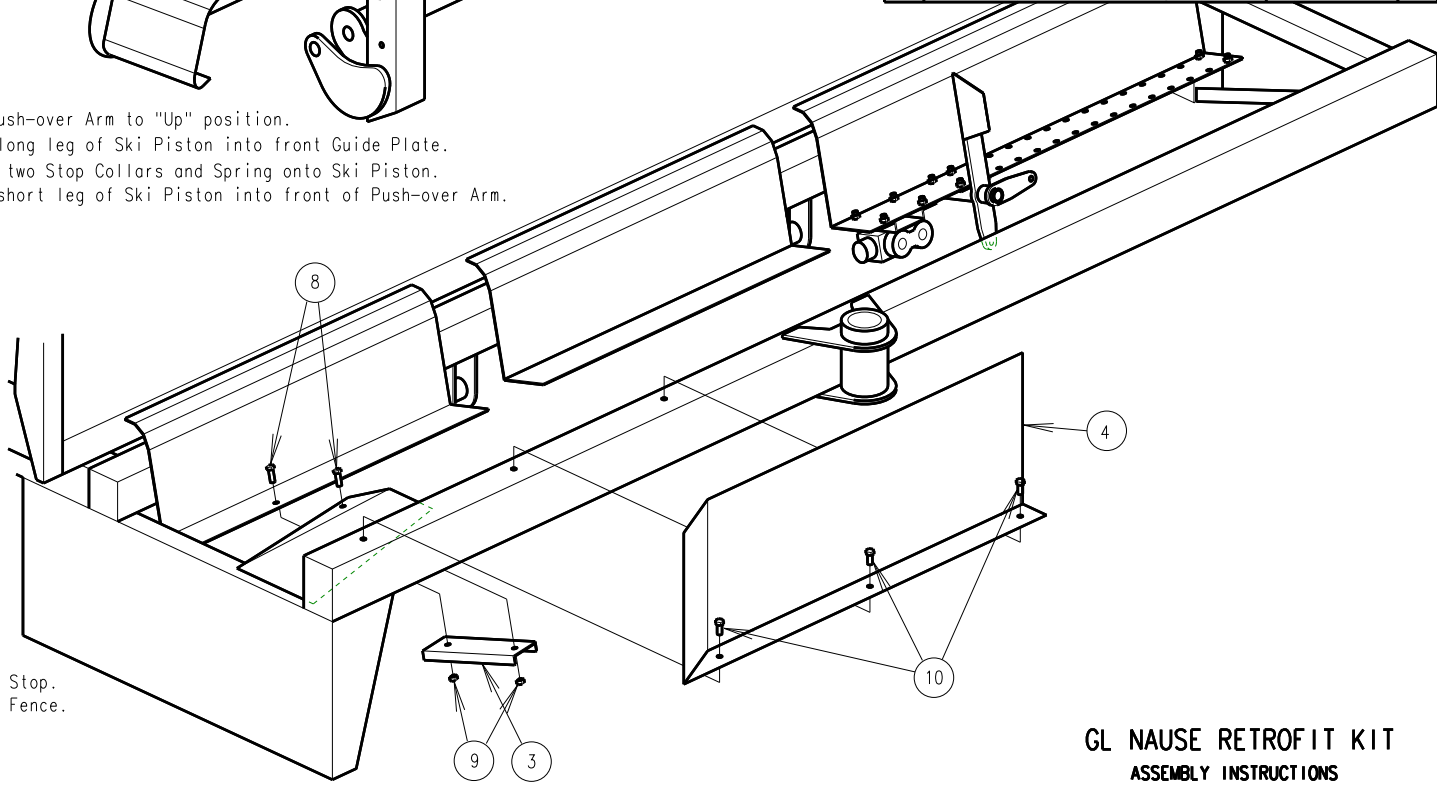

**Fig. 3**

1. Drill holes for, and install Bale Stop.
2. Drill holes for, and install Bale Fence.

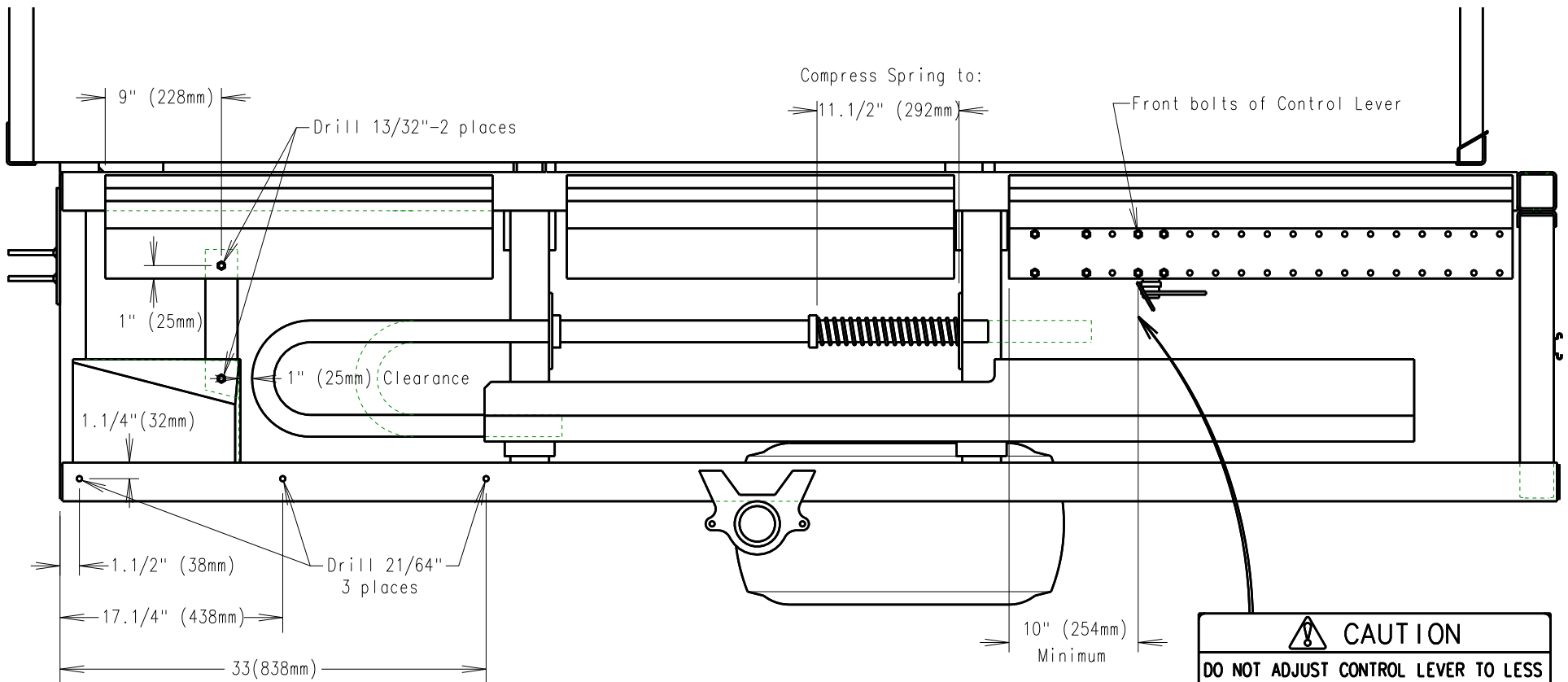

**CAUTION**

DO NOT ADJUST CONTROL LEVER TO LESS THAN 10" FROM FRONT OF THIS CHUTE. DAMAGE COULD RESULT.

36"-39" bales may be accommodated from this location.

**GL NAUSE RETROFIT KIT**  
ADJUSTMENT INSTRUCTIONS